

# KMA 495

## Pneumatically Operated Valve DN 15 - 100 mm (1/2" - 4")



Cf. 1

### Features

- Thermoplastic diaphragm actuator with stainless steel distance piece
- Control air connection 90° to flow direction
- Flexible diaphragm suspension
- Encapsulated diaphragm

### Optional

- Available with a wide range of control equipment and accessories see page 57 to 62, also for retrofitting

### Technical Data

Control function (Cf.): Pneumatically operated  
 Normally closed (NC): Cf. 1  
 Normally open (NO): Cf. 2  
 Double acting (DA): Cf. 3

Direction: At Cf. 1, 2 & 3, 90° to flow direction, standard

Control connection: G1/4 to flow direction, standard

Max. working pressure: Unidirectional ( $\Delta p = 100\%$ )

Diaphragm	DN 15-50 (2")	DN 65-80 (2,5"-3")	DN 100 (4")
EPDM	10 bar (150 psi)	7 bar (100 psi)	6 bar (90 psi)
PTFE	8 bar (120 psi)	6 bar (90 psi)	5 bar (75 psi)

Higher working pressure may be achieved with different actuator.  
 Please contact us for working pressure above the indicated maximum.

Max. working temperature: 175°C (350°F) dependent on application

Control pressure:

Cf. 1	DN 15 - 50	4,5 - 6 bar (65-90 psi)
Cf. 1	DN 65 - 80	4,5 - 7 bar (65-100 psi)
Cf. 1	DN 100	5,5 - 7 bar (90-100 psi)
Cf. 2 & 3	DN 15 - 80	4 - 5,5 bar (60-80 psi)
Cf. 2 & 3	DN 100	5 - 6,5 bar (70-95 psi)

Diaphragm material: EPDM or PTFE

Valve body material: Forged 1.4435/ 316 L ASME/BPE  
 Investment cast 1.4435/ 316 L  
 Other alloys

End connection: Butt weld ends see fold out page 13  
 Clamps and flanges see page 14 and 15  
 Special ends

Actuators suitable for: Two-Way bodies  
 Welded configurations  
 T-bodies  
 Multiport bodies  
 Tank bottom bodies

Flow rate: Kv in m<sup>3</sup>/h (Cv in GPM) see page 7

Diaphragm size: MA see table below

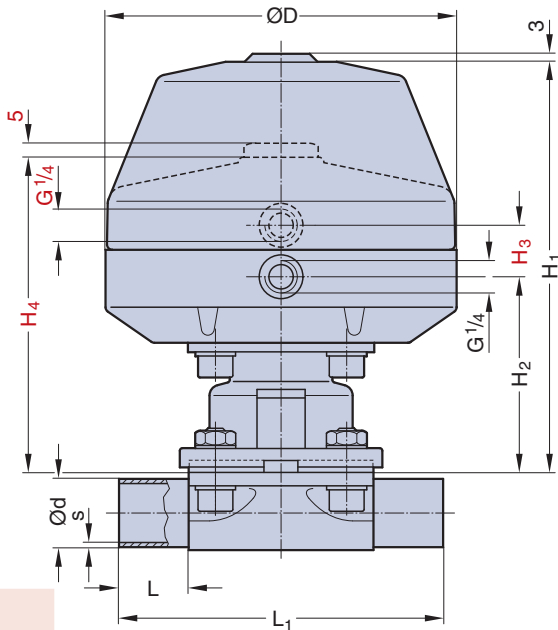

Butt weld ends  
 MA 25 - 100  
 Fold out page 13

DN (mm)	Dimensions (mm)							
	MA	L	L <sub>1</sub>	H <sub>1</sub>	H <sub>2</sub>	H <sub>3</sub>	H <sub>4</sub>	D
15-25	25	25	120	153	71	31	120	130
32-40	40	25	153	194	95	31	144	161
50	50	30	173	233	109	31	177	217
65	80	30	216	314	166	41	275	265
80	80	30	254	314	166	41	275	265
100	100	30	305	314	166	41	284	265

Note: H3 and H4 only for valves with Cf. 2 and Cf. 3  
 H1 only for valve with Cf. 1