

### FEATURES

- Control of high-pressure fluids
- NAMUR interface pilot for 1/4" solenoid spool valve
- Valve without actuator gland designed for long service life
- Vacuum operation up to 10<sup>-4</sup> mbar
- The valves satisfy article 3.3 of Pressure Equipment Directive 97/23/EC

### GENERAL

<b>Differential pressure</b>	[1 bar = 100 kPa]
pilot 3/2 NC	A → B : 40 bar, B → A : 12 bar
pilot 5/2	A → B : 40 bar, B → A : 40 bar
<b>Ambient temperature range</b>	-20°C to +100°C
<b>Maximum viscosity</b>	
pilot 3/2 NC	500 cSt (mm <sup>2</sup> /s)
pilot 5/2	6000 cSt (mm <sup>2</sup> /s)
<b>Pilot fluid</b>	Air or oil
<b>Pilot pressure</b>	4 to 8 bar
<b>Pilot fluid temperature</b>	0°C to +60°C
<b>Response time</b> (air operation ΔP = 4 bar)	
opening (ms)	3/8 1/2 3/4 1
closing (ms)	30 35 40 50
	50 60 60 70

fluids (*)	temperature range (TS)	seal materials (*)
air and gas groups 1 & 2	- 20°C to + 100°C	FPM (fluoroelastomer)
water, oil, liquids groups 1 & 2		PTFE

### MATERIALS IN CONTACT WITH FLUID

(\*) Ensure that the compatibility of the fluids in contact with the materials is verified

	Brass body	Stainless steel body
<b>Body</b>	Brass	Stainless steel
<b>Internal parts</b>	Brass	Stainless steel
<b>Tube</b>	Stainless steel	Stainless steel
<b>Seals</b>	FPM	FPM
<b>Disc seal</b>	PTFE	PTFE

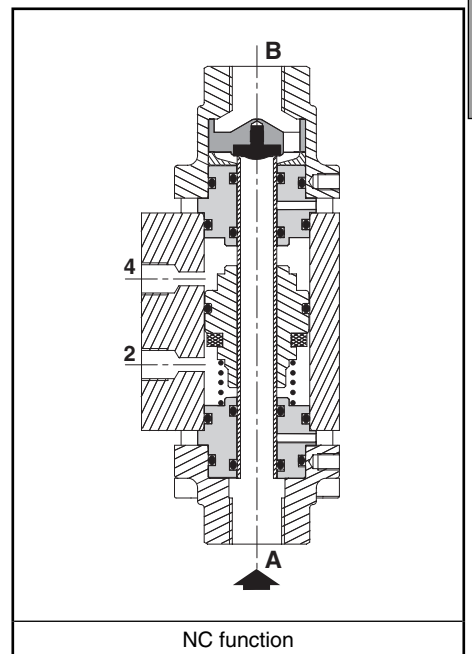

### SPECIFICATIONS

pipe size	DN	flow coefficient Kv		operating pressure differential (bar)				catalogue number	
				min.	max. (PS)				
					air/gas/water/oil (*)				
G		(m <sup>3</sup> /h)	(l/min)		B → A	A → B	brass	stainless steel	
<b>NC - Normally closed</b>									
3/8	10	2,2	36,6	0	12	40	<b>G287A101</b>	<b>G287A109</b>	
1/2	15	5,2	86,6	0	12	40	<b>G287A102</b>	<b>G287A110</b>	
3/4	20	7,5	125	0	12	40	<b>G287A103</b>	<b>G287A111</b>	
1	25	12,2	203,3	0	12	40	<b>G287A104</b>	<b>G287A112</b>	
<b>NO - Normally open</b>									
3/8	10	2,2	36,6	0	12	40	<b>G287A105</b>	<b>G287A113</b>	
1/2	15	5,2	86,6	0	12	40	<b>G287A106</b>	<b>G287A114</b>	
3/4	20	7,5	125	0	12	40	<b>G287A107</b>	<b>G287A115</b>	
1	25	12,2	203,3	0	12	40	<b>G287A108</b>	<b>G287A116</b>	

### OPTIONS

- ATEX 94/9/EC versions for use in zones 1/21-2/22, categories 2-3, use suffix GD2 (example: G287A101GD2)
- Magnetic position detectors (MR) "T profile":
  - with 2 m PVC lead, 3 wires 0,14 mm<sup>2</sup>, stripped and tinned ends, catalogue number: **88100737**
  - with 5 m PVC lead, 3 wires 0,14 mm<sup>2</sup>, stripped and tinned ends, catalogue number: **88100738**
  - with 0,15 m PVC lead + plug-in male connector Ø M8 - 3 pins, catalogue number: **88100739**
  - with 0,15 m PVC lead + screw-type male connector Ø M12 - 3 pins, catalogue number: **88100740**

### INSTALLATION

- The valves can be mounted in any position without affecting operation
- Valves have two mounting holes in body
- Pipe connection identifier is G = G (ISO 228/1)
- Installation/maintenance instructions are included with each valve

### SPARE PARTS KITS & ACCESSORIES

catalogue number	spare parts kit no.		mounting bracket no.
	brass	stainless steel	
G287A101/109/105/113	<b>C140176</b>	<b>C140177</b>	<b>C140130</b>
G287A102/110/106/114	<b>C140180</b>	<b>C140181</b>	<b>C140131</b>
G287A103/111/107/115	<b>C140184</b>	<b>C140185</b>	<b>C140132</b>
G287A104/112/108/116	<b>C140188</b>	<b>C140189</b>	<b>C140133</b>

### ORDERING EXAMPLES:

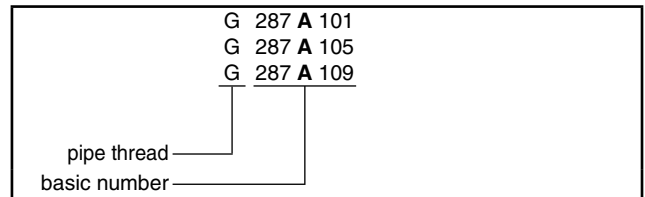

### DIMENSIONS (mm), WEIGHT (kg)



**TYPE 01**  
NAMUR interface pilot

### ORDERING EXAMPLES KITS:

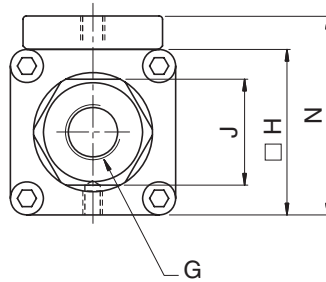
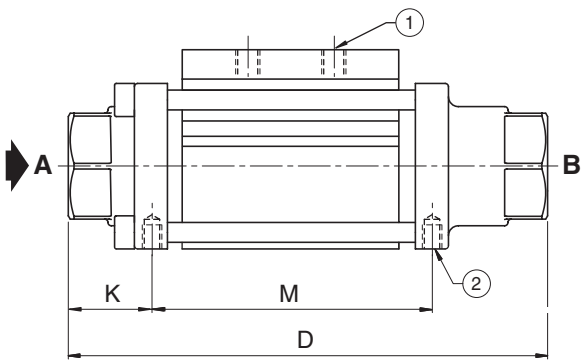
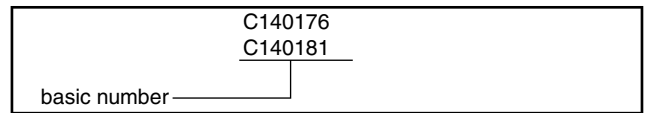

- ① 2 pilot ports G 1/8
- ② 2 mounting holes Ø M5, depth 7 mm

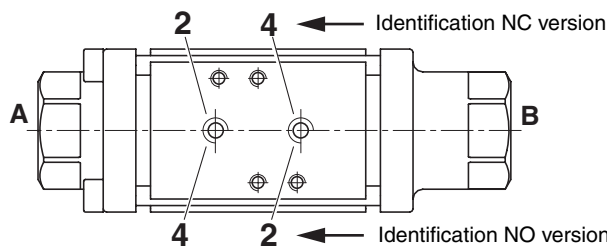

type	G	D	H	J	K	M	N	X	Y	Z	weight <sup>(1)</sup>
01	3/8	145	50	32	25	85	60	24	111	6	1,3
	1/2	173	70	41	31	103	68	38	136	6	2,5
	3/4	193	80	46	35	111	78	45	151	7	3,8
	1	212	90	55	36	121	88	50	165	7	5,1

<sup>(1)</sup> Without mounting brackets.

NAMUR interface pilot operation

<p>position detectors</p>	<p>mounting brackets</p>	<p>NAMUR solenoid valves, series 551</p>
---------------------------	--------------------------	--