

### INTRODUCTION

In selecting a valve, a number of operating and physical parameters must be considered. The operating parameters include opening pressure, flow, pressure drop, temperature and maximum pressure the valve may experience. The physical parameters are pipe size and type of fluid. In this section we concentrate on the operating parameters.

#### ● PRESSURES

#### MAXIMUM OPERATING PRESSURE DIFFERENTIAL - MOPD (PS)

When the valve is closed, the supply pressure is present at the inlet port only. This is the pressure the valve has to open against. In other words, this is the pressure the electrical solenoid has to overcome to open the valve and allows flow to occur. This pressure is called Maximum Operating Pressure Differential (PS) or simply "MOPD" in our catalogue. The value given in the catalogue must be equal to or greater than the maximum pressure at the supply port at which the valve must open. Note it is not always the same for different types of fluid and that AC valves usually have higher pressure ratings than DC valves.

Strictly speaking, the MOPD is the maximum pressure drop across the valve when the valve is closed. If there is a pressure at the outlet port when the valve has to open, this could be subtracted from the inlet pressure to arrive at the MOPD. However, if at some time a zero pressure is present at the outlet, the valve will have to open at the pressure at the inlet which may be too high, causing possible coil burnout on an AC source. Therefore, the supply pressure is considered as the MOPD in conservative designs.

#### MINIMUM OPERATING PRESSURE DIFFERENTIAL

Once the valve has opened, the pressure conditions may change. A pressure is present at the valve outlet. This pressure may be negligible as when the valve is filling a tank, or it could be quite high when the valve supplies a spray nozzle. In some cases, the pressure at the supply and outlet will be the same when a cylinder has moved and we have in effect a dead-end load. When the pressures are equal, the fluid has ceased to flow.

If we call the supply port pressure  $P_1$  and the outlet port pressure  $P_2$ , the pressure drop across the valve is  $P_1 - P_2$ . We also call this the pressure differential ( $\Delta P$ ) across the valve.

**Example:** if  $P_1$  was 10 bar and  $P_2$  was practically zero, which would be the case if water was flowing out of the valve into a tank, the pressure drop or differential would be  $\Delta P = P_1 - P_2$ ; that is  $10 - 0 = 10$  bar. Now: if  $P_2$  was 9 bar due to a nozzle  $\Delta P$  would equal  $10 - 9 = 1$  bar

(The minimum operating pressure differential is the minimum pressure drop that will exist across the valve when there is flow).

In selecting a valve, check if a minimum operating pressure differential column is applicable to the valve you are considering. If there is no column or the number in the column is zero, the valve will remain open even if the pressures at the inlet and outlet are the same. If there is such a column, make sure that the minimum pressure drop in the system never gets below the figure shown or the valve will throttle, causing fluctuation in flow.

#### MAX. ALLOWABLE PRESSURE

(According to EN 764)

The maximum allowable pressure is the maximum line or system pressure the valve can be subjected to in normal service. Due to limitations on the maximum pressure test we can conduct on our production test stands, the figures shown may be conservative. If higher safe working pressures are required, please contact your local ASCO/JOUCOMATIC sales office.

Pressures up to the maximum allowable pressure can occur when the valve is open or closed and may damage the valve internal parts if exceeding the MOPD.

#### PROOF PRESSURE

All valve designs are tested for proof pressures up to five (5) times the maximum allowable pressure. This is a destructive test and only ensures that no external damage will occur up to the proof pressure. Above five (5) times the pressure, external damage may occur.

#### ● TEMPERATURES

##### Normal ambient temperature

The normal ambient temperature is assumed to be in accordance with standard conditions as specified in ISO 554

ambient temperature	: 20°C
ambient pressure	: 1013 mbar
relative humidity	: 65%

##### Maximum ambient temperature (TS)

The maximum ambient temperature listed (20°C) is based on test conditions to determine safe limits for coil insulation. The temperature is determined under continuously energized conditions and with maximum fluid temperatures (as listed) existing in the valve. In many applications the existing specific conditions will permit use at higher ambient temperatures. Refer to Coil Section J, page V1100. In addition, modifications to standard constructions are available which can extend the maximum ambient temperature limitation to 80°C or more.

##### Minimum ambient temperature

The minimum ambient temperature of a valve is greatly affected by application and construction.

**Damage may occur when liquids solidify above the specified minimum temperature.**

Special constructions are available for lower temperatures, consult ASCO/JOUCOMATIC for these applications.

##### Maximum fluid temperature (TS)

The maximum fluid temperature listed is valid for an ambient temperature of 20°C and 100% RD (Relative Duty Time). In case of higher fluid temperatures, refer to Coil Section J, page V1100.

#### ● VISCOSITY

Viscosity is the resistance of a fluid to flow, due to internal friction. Viscosity affects the flow rate of a valve considerably and the flow factor is reduced when viscous fluids are to pass the valve.

There are two types of viscosity:

- a) dynamic viscosity, expressed in Pa.s (Pascal seconds) or Poises
- b) kinematic viscosity, which is the ratio between dynamic viscosity and density of the fluid

Kinematic viscosity is expressed in mm<sup>2</sup>/s or cStokes; in this catalogue only kinematic viscosity is considered.

Although the official unit for kinematic viscosity according to ISO-R3 is m<sup>2</sup>/s, the following units are generally used.

Centistokes (mm <sup>2</sup> /s)	cStokes	1	12	22	30	38	45	60	75	90	115	150	200	300	400	500	750	1500
° Engler	°E	1	2	3	4	5	6	8	10	12	15	20	26	39	53	66	97	197
Saybolt Universal Seconds	SSU	28	65	100	140	175	210	275	345	415	525	685	910	1385	1820	2275	3365	6820
Redwood Seconds (n° 1)	SRW n° 1	27	55	90	120	155	185	245	305	370	465	610	810	1215	1620	2025	2995	6075

- Centistokes (  $\frac{1}{100}$  Stoke ) = 1 mm<sup>2</sup>/s:  
cStokes

- °Engler : °E

- Saybolt Universal Seconds : SSU

- Redwood Seconds no. 1 : SRW n° 1

There are no common factors between these units and the official S.I. system. The table above should be an aid to compare the various units.

Viscosity is greatly dependent on temperature and to know the actual viscosity of a fluid the real fluid temperature must be considered.

### Oil grades

Both hydraulic and fuel oils are classified relative to viscosity and are roughly distinguished in heavy and light oils.

Viscosity specifications listed below are commonly applied by the fuel oil suppliers and are always given for specified temperatures.

1. Light oils - viscosity at 20°C up till:  
65 cSt / 8,5°E / 300 SSU /  
265 SRW no. 1
2. Fuel oil grade 2 - viscosity limits at 20°C:  
3,5-8,5 cSt / 1,3-1,7°E / 40-55 SSU /  
35-45 SRW no. 1
3. Fuel oil grade 4 - viscosity limits at 38°C:  
9-26 cSt / 1,8-3,5°E / 45-125 SSU /  
40-110 SRW no. 1
4. Fuel oil grade 5 - viscosity limits at 38°C:  
light: 30-65 cSt / 4-8,5°E /  
140-300 SSU / 120-265 SRW no. 1  
heavy: 75-160 cSt / 10-21°E /  
320-750 SSU / 265-660 SRW no. 1
5. Fuel oil grade 6 - viscosity limits at 50°C:  
90-640 cSt / 12-85°E / 415-3000 SSU  
37-2650 SRW no. 1

### ● RESPONSE TIMES:

This is the time-lapse after energizing (or de-energizing) a solenoid valve until the outlet pressure reaches a specific percentage of its maximum steady value, the outlet being connected to a circuit having specified flow parameters.

Response time depends on 5 factors:

- kind of electrical supply: AC or DC
- fluid handled by the valve, viscosity and pressure level
- type of operation: direct or pilot operated
- size of the moving parts of the valve mechanism
- circuit in which the time is measured

- a) small direct acting valves: 5 - 25ms
- b) large direct acting valves: 20 - 40ms
- c) internal pilot operated valves:
  - 1) small diaphragm type: 15 - 60ms
  - 2) large diaphragm type: 40 - 120ms
  - 3) small piston type: 75 - 100ms
  - 4) large piston type: 100 - 1000ms

Generally speaking, operation on liquid media will have the following effects:

- a) small direct acting valves ± 20-30% higher
- b) large direct acting and internally pilot operated valves: dependant on size 50-150% higher

The exact values are listed on the appropriate pages.

Approximate values for AC valves on air service under average conditions are:

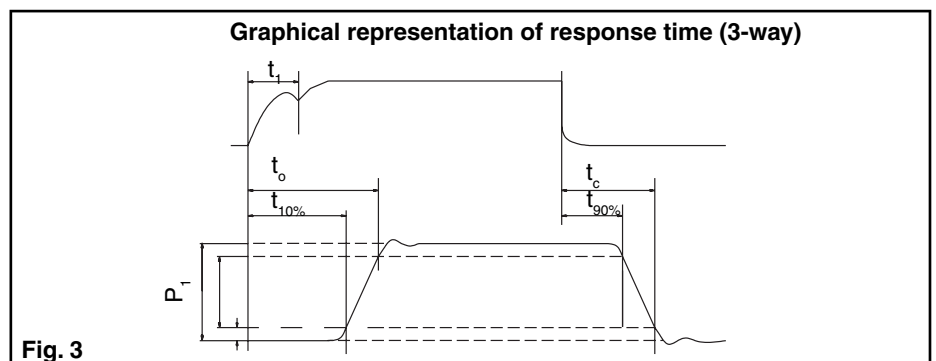
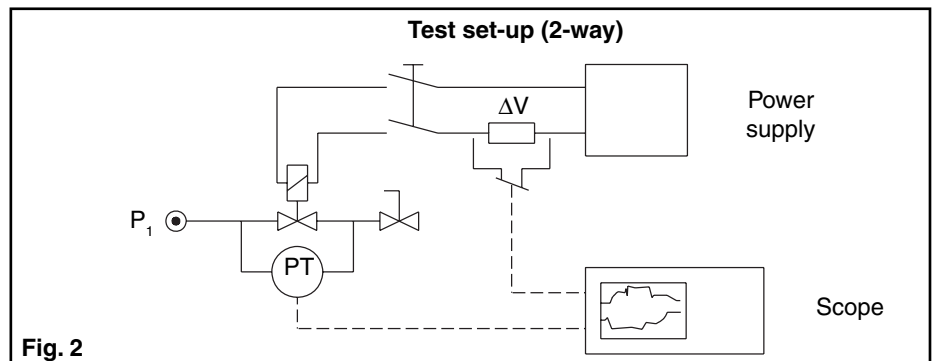
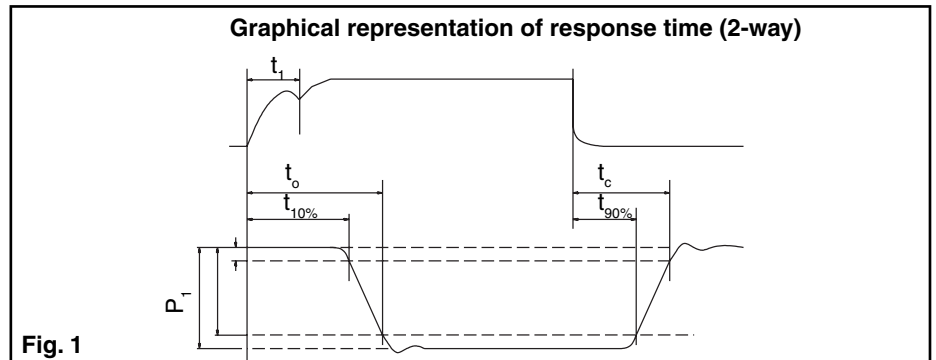

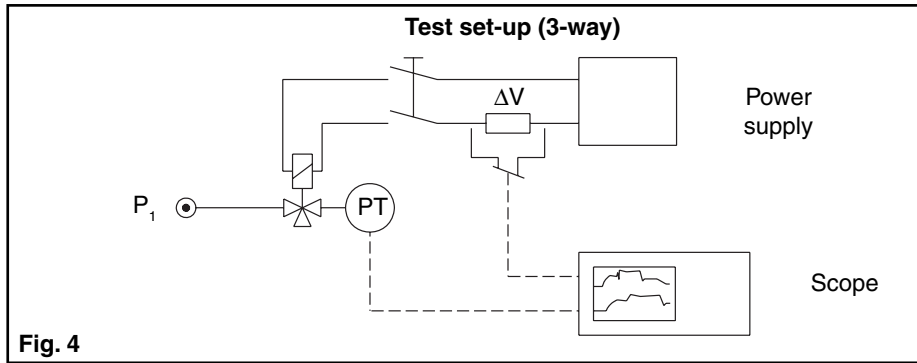

Fig. 4

### Graphics legend

- $p_1$  = inlet pressure
- PT = pressure transducer
- $\Delta V$  = voltage drop
- $t_1$  = core pick-up time
- $t_o$  = opening time
- $t_c$  = closing time
- $t_{10\%}$  = 10% open/10% closed
- $t_{90\%}$  = 90% open/90% closed

Response time on DC operation is approximately 60% higher than on AC operation.

Consult us if response time is a critical factor.

The ratings below are associated with the speed of response of self contained pilot operated valves, using the flowing stream as the operating media.

Excellent:	0 to 500	SSU
Good:	500 to 1000	SSU
Satisfactory:	1000 to 2000	SSU
Fair:	2000 to 5000	SSU
Unsatisfactory:	above 5000	SSU

Normally a valve application that falls into the fair category performs or responds very slow with regulating pilots such as pressure reducing, back pressure or pressure relief. A solenoid on-off valve will perform satisfactorily provided an overrun can be compensated for.

### Electrically operated directional control valves

The switching time of an electrically operated directional control valve is the time which elapses between the closing or opening of the electric circuit and the instant when the pressure at the outlet port reaches 50% of its maximum value, the outlet port being blocked at the valve body or at the sub-plate if the valve is mounted on a sub-plate.

### Electric (direct operated)

The switching threshold of a direct electrically operated valve is the limiting value of the electric voltage, rising or falling, which causes or allows "switching", i.e. the complete transition from an initial to a final state under the normal operating conditions foreseen by the manufacturer (no oscillation, correct sealing, normal flow values, etc.).

### Electric (pilot operated)

Here consider only the case where the medium causing switching is compressed air coming either from the main inlet port or from an external auxiliary port.

The switching threshold of an electric pilot operated valve is the joint effect of two limiting values, rising or falling; on the one hand the signal pressure and on the other the signal voltage, which cause or allow "switching", i.e. the complete transition from an initial to a final state under the normal operating conditions foreseen by the manufacturer (no oscillation, correct sealing, normal flow values, etc.).

The above definitions are based on CETOP recommendation RP 111P.

### ● VALVE SEAT TIGHTNESS:

Valve seat tightness or leakage depends on the type of valve, used sealing materials trim and medium.

Although it is expected that a big orificed piston valve with a high DURO disc will show some more leakage flow than a simple core-disc execution with soft resilients. To establish practical test leakage flow rates for the ASCO/JOUCOMATIC valves the following 3 groups (categories) are applicable for all valve types and/or sizes.













- 1) Leakage flow < 0,24 N dm<sup>3</sup>/h within the specified pressure range of the valve product (all resilient disc, diaphragm or poppet closing members such as NBR, FPM, EPDM, TPE, UR, etc.).
- 2) Leakage flow < 0,084 N m<sup>3</sup>/h within the specified pressure range of the valve product (all non-resilient disc or other closing members such as PTFE, reinforced PTFE, metal, POM, etc.).
- 3) Leakage flow for "Gas Approved Valves" see table below (according to EN 161).

Nominal orifice DN	Allowable leakage in N cm <sup>3</sup> /h air	
	internal leaktightness	external leaktightness
DN < 10	20	20
10 ≤ DN < 25	40	40
25 ≤ DN < 80	60	-
80 ≤ DN < 150	100	60
150 < DN	150	-

### DEGREES OF PROTECTION PROVIDED BY ELECTRICAL ENCLOSURES (IP Code)

(according to standards EN 60529 and IEC 529)

The code letters IP (Ingress Protection) followed by 2 characteristic numerals: e.g. IP65. The first figure indicates the degree of protection of the energized parts and internal moving parts against ingress of solid foreign objects. The second figure indicates the degree of protection against ingress of water with harmful effects.

1st NUMERAL		Test	2nd NUMERAL		Test
	Abridged definition			Abridged definition	
0	Non-protected		0	Non-protected	
1	Protected against solid foreign objects Ø 50 mm (eg accidental contact with the hand)		1	Protected against vertically falling water drops (condensation)	
2	Protected against solid foreign objects Ø 12,5 mm (eg finger)		2	Protected against vertically falling water drops when enclosure tilted up to 15°	
3	Protected against solid foreign objects Ø 2,5 mm (eg tools, wires)		3	Protected against spraying water up to 60° on either side of the vertical	
4	Protected against solid bodies Ø 1 mm (eg fine tools and small wires)		4	Protected against splashing water from any direction	
5	Dust-protected (no harmful deposit)		5	Protected against water jets from any direction	
6	Dust-tight		6	Protected against powerful water jets from any direction	
			7	Protected against the effects of temporary immersion in water	

The degree of protection of each product is indicated in its appropriate leaflet, usually IP 65.